



TECHNICAL GUIDE

80% TWO STAGE VARIABLE SPEED ECM MULTI-POSITION RESIDENTIAL GAS FURNACES STANDARD & LOW NO_x

MODELS: TM8V*C / TMLV*C

NATURAL GAS

60 - 120 MBH INPUT



Due to continuous product improvement, specifications are subject to change without notice.

Visit us on the web at www.york.com

Additional rating information can be found at

www.ahridirectory.org

WARRANTY SUMMARY

A 20-year limited warranty on heat exchangers in residential applications.

A 10-year warranty on the heat exchanger in commercial applications.

Standard 5-year limited Parts warranty.

Extended residential limited lifetime heat exchanger and 10-year limited parts warranty when product is registered online within 90 days of purchase for replacement or within 90 days of closing for new home construction.

See Limited Warranty certificate in Users Information Manual for details.

DESCRIPTION

These compact units employ induced combustion, reliable hot surface ignition and high heat transfer aluminized tubular heat exchangers. The units are factory shipped for installation in upflow or horizontal applications and may be converted for downflow applications.

These furnaces are designed for residential installation in a basement, closet, alcove, attic, recreation room or garage and are also ideal for commercial applications. All units are factory assembled, wired and tested to assure safe dependable and economical installation and operation.

These units are Category I listed and may be common vented with another gas appliance as allowed by the National Fuel Gas Code.

FEATURES

- Two stage heating operation includes two stage gas valve, two stage inducer operation and variable speed ECM blower operation. Adjustable delay timer allows two stage operation with a single stage thermostat.
- Easily applied in upflow, horizontal left or right, or downflow installation with minimal conversion necessary.
- Compact, easy to install, ideal height 33" tall cabinet.
- ECM variable speed drive for cooling SEER enhancement, improved comfort with optional airflow delay profiles, and continuous fan options for IAQ performance.
- Easy access to controls to connect power/control wiring.
- Built-in, high level self diagnostics with fault code display.
- Low unit amp requirement for easy replacement application.
- All models are convertible to use propane (LP) gas.
- Electronic Hot Surface Ignition saves fuel cost with increased dependability and reliability.
- 100% shut off main gas valve for extra safety.
- 24V, 40 VA control transformer and blower relay supplied for add-on cooling.
- Hi-tech tubular aluminized steel primary heat exchanger.
- Solid removable bottom panel allows easy conversion.
- Airflow leakage less than 1% of nominal airflow for duct performance testing conditions.
- No knockouts to deal with, making installation easier.
- Movable duct connector flanges for application flexibility.
- Quiet inducer operation, burner, and blower operation.
- Inducer rotates for easy conversion of venting options.
- Fully supported blower assembly for easy access and removal of blower.
- External air filters used for maximum flexibility in meeting customers IAQ needs.
- Insulated blower compartment for thermal and acoustic performance.
- Low NO_x models have been designed to meet specific code requirements.
- Venting applications - may be installed as a common vent with other gas-fired appliances or use a masonry chimney.
- 1/4 turn knobs provided for easy independent door removal.
- These models may be connected as part of a communicating control system using a 4-wire connection bus.

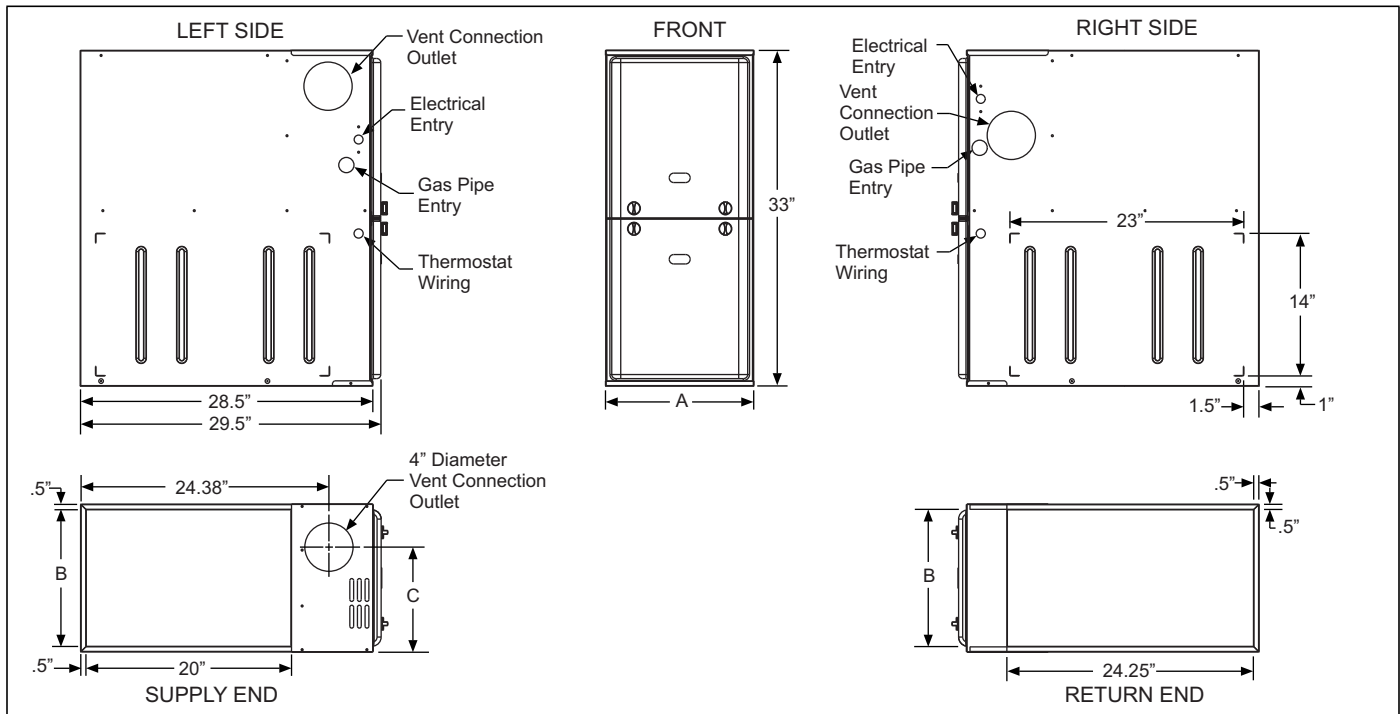

Cabinet & Duct Dimensions

Model	Nominal CFM (m ³ /min)	Cabinet Size	Cabinet Dimensions (Inches)		
			A	B	C
TM(8,L)V060A12MP12C	1200	A	14 1/2	13 3/8	10.3
TM(8,L)V080B12MP12C	1200	B	17 1/2	16 3/8	11.8
TM(8,L)V080C16MP12C	1600	C	21	19 7/8	13.6
TM(8,L)V100C16MP12C	1600	C	21	19 7/8	13.6
TM(8,L)V100C20MP12C	2000	C	21	19 7/8	13.6
TM(8,L)V120C20MP12C	2000	C	21	19 7/8	13.6

Ratings & Physical / Electrical Data

Models	Input High/Low		Output High/Low		Nominal Airflow	Total Unit Amps	Recommended Fuse or Circuit Breaker	Max. Outlet Air Temp
	MBH	MBH	CFM	Amps			°F	
TM(8,L)V060A12MP12C	60/39	47/31	1200	10.3	15	190		
TM(8,L)V080B12MP12C	80/52	63/42	1200	10.3	15	190		
TM(8,L)V080C16MP12C	80/52	63/42	1600	12.2	15	190		
TM(8,L)V100C16MP12C	100/65	80/52	1600	12.1	15	190		
TM(8,L)V100C20MP12C	100/65	80/52	2000	15.3	20	190		
TM(8,L)V120C20MP12C	120/78	96/62	2000	15.3	20	190		
Models	High Fire Air Temp. Rise	Low Fire Air Temp. Rise	Blower		Blower Size	AFUE	Gas Pipe Connection, NPT	Operating Weight
	°F	°F	HP	Amps	Inches	%		Lbs.
TM(8,L)V060A12MP12C	30-60	15-45	1/2	7.7	11 x 8	80.0	1/2"	94
TM(8,L)V080B12MP12C	30-60	20-50	1/2	7.7	11 x 8	80.0	1/2"	103
TM(8,L)V080C16MP12C	30-60	20-50	3/4	9.6	11 x 10	80.0	1/2"	114
TM(8,L)V100C16MP12C	30-60	20-50	3/4	9.6	11 x 10	80.0	1/2"	118
TM(8,L)V100C20MP12C	30-60	20-50	1	12.8	11 x 11	80.0	1/2"	122
TM(8,L)V120C20MP12C	30-60	20-50	1	12.8	11 x 11	80.0	1/2"	129

Annual Fuel Utilization Efficiency (AFUE) numbers are determined in accordance with DOE Test procedures. Wire size and over current protection must comply with the National Electrical Code (NFPA-70-latest edition) and all local codes. The furnace shall be installed so that the electrical components are protected from water.

HORIZONTAL SIDEWALL VENTING

For applications where vertical venting is not possible, the only approved method of horizontal venting is the use of an auxiliary power vent. Auxiliary power venters must be approved by CSA, UL, or other recognized safety agencies. Follow all application and installation details provided by the manufacturer of the power vent.

FILTER PERFORMANCE

CAUTION

In downflow furnace arrangement, the filter must be located a minimum of 12" from the return air inlet of furnace.

The airflow capacity data published in the "Blower Performance" table shown represents blower performance **WITHOUT** filters.

All applications of these furnaces require the use of field installed air filters. All filter media and mounting hardware or

Unit Clearances to Combustibles (All dimensions in inches, and all surfaces identified with the unit in an upflow configuration)

Application	Top	Front	Rear	Left Side	Right Side	Flue	Floor/Bottom	Closet	Alcove	Attic	Line Contact
Upflow	1	1	0	0	0	6	Combustible	Yes	Yes	Yes	No
Upflow B-Vent	1	1	0	0	0	1	Combustible	Yes	Yes	Yes	No
Downflow	1	1	0	0	0	6	1 ¹	Yes	Yes	Yes	No
Downflow B-Vent	1	1	0	0	0	1	1 ¹	Yes	Yes	Yes	No
Horizontal	1	1	0	0	0	6	Combustible	No	Yes	Yes	Yes ²
Horizontal B-Vent	1	1	0	0	0	1	Combustible	No	Yes	Yes	Yes ²

1. Special floor base or air conditioning coil required for use on combustible floor.

2. Line contact only permitted between lines formed by the intersection of the rear panel and side panel (top in horizontal position) of the furnace jacket and building joists, studs or framing.

ACCESSORIES

Propane (LP) Conversion Kit - This accessory conversion kit may be used to convert natural gas units for LP operation.

S1-1NP0347 - All Models

LP Stainless Steel Burner Kit - This accessory conversion kit may be used to convert existing burners to stainless steel burners for LP use only.

S1-32926889000 - All LP Models

Natural (NAT) Gas Stainless Steel Burner Kit - This accessory kit may be used to replace existing burners with stainless steel burners for NAT gas use only.

S1-32924441000 - All NAT gas Models

Side Return Filter Racks - The S1-1SR0200 Kit accommodates a 1", 2" or 4" filter. The S1-1SR0402 Kit accommodates a 1" filter only.

S1-1SR0200 - All Models

S1-1SR0402 - All Models

Bottom Return Filter Racks - The S1-1BR05* series are galvanized steel filter racks. The S1-1BR06* series are pre-painted steel filter racks to match the appearance of the furnace cabinet. The S1-1BR05* and S1-1BR06* series filter racks accommodate a 1", 2" or 4" filter.

S1-1BR0514 or 1BR0614 - For 14-1/2" cabinets

S1-1BR0517 or 1BR0617 - For 17-1/2" cabinets

S1-1BR0521 or 1BR0621 - For 21" cabinets

provisions must be field installed external to the furnace cabinet. **DO NOT** attempt to install any filters inside the furnace.

NOTICE

Single side return above 1800 CFM is approved as long as the filter velocity does not exceed filter manufacturer's recommendation and a transition is used to allow use on a 20x25 filter.

Recommended Filter Sizes

CFM	Cabinet Size	Side (inches)	Bottom (inches)
1200	A	16 x 25	14 x 25
1200	B	16 x 25	16 x 25
1600	C	16 x 25	20 x 25
2000	C	(2) 16 x 25	20 x 25

1. Air velocity through throwaway type filters may not exceed 300 feet per minute (91.4 m/min). All velocities over this require the use of high velocity filters.

2. Do not exceed 1800 CFM using a single side return and a 16x25 filter. For CFM greater than 1800, you may use two side returns or one side and the bottom or one return with a transition to allow use of a 20x25 filter.

Masonry Chimney Kits - This accessory kit allows upflow 80% models to be vented into a tile-lined masonry chimney.

S1-1CK0604 - All 80% Non-modulating Models

Combustible Floor Base Kit - These kits are required to prevent potential overheating situations when the furnaces are installed in downflow applications directly onto combustible flooring material. These kits are also required in any applications where the furnace is installed in a downflow configuration without an indoor coil and where the combustible floor base kit provides access for combustible airflow.

S1-1CB0514 - For 14-1/2" cabinets

S1-1CB0517 - For 17-1/2" cabinets

S1-1CB0521 - For 21" cabinets

High Altitude Pressure Switches - For installation where the altitude is less than 5,000 feet, it is not required that the pressure switch be changed. For altitudes above 5,000 feet, see kits below.

S1-1PS3309

Thermostats - Compatible thermostat controls are available through accessory sourcing. For optimum performance, these outdoor units are fully compatible with our York touch screen thermostat with proprietary (patent-pending) hexagon interface. For more information, see the thermostat section of the Product Equipment Catalog.

S1-THXU280 - All Models

Air Flow Data

HIGH / LOW SPEED COOLING AND HEAT PUMP CFM							
TM(8,L)V060A12MP12C		TM(8,L)V080B12MP12C		TM(8,L)V080C16MP12C		Jumper Settings	
HIGH COOL	LOW COOL	HIGH COOL	LOW COOL	HIGH COOL	LOW COOL	COOL Jumper	ADJ Jumper
1277	825	1241	834	1644	1054	A	B
1067	709	1064	720	1447	927	B	B
1162	762	1147	782	1489	955	A	A
972	667	960	678	1321	857	B	A
1046	699	1043	709	1349	871	A	C
857	615	855	605	1236	815	C	B
888	615	866	615	1166	787	B	C
678	499	678	501	1012	703	D	B
783	573	793	563	1096	759	C	A
625	478	626	459	927	660	D	A
720	531	720	521	998	703	C	C
583	478	574	459	843	604	D	C
TM(8,L)V100C16MP12C		TM(8,L)V100C20MP12C		TM(8,L)V120C20MP12C		Jumper Settings	
HIGH COOL	LOW COOL	HIGH COOL	LOW COOL	HIGH COOL	LOW COOL	COOL Jumper	ADJ Jumper
1674	1069	2244	1380	2244	1437	A	B
1463	943	1744	1149	1783	1188	B	B
1519	971	2032	1284	2032	1322	A	A
1336	858	1572	1053	1610	1072	B	A
1378	1013	1821	1149	1840	1188	A	C
1238	816	1495	1015	1533	1034	C	B
1168	788	1399	957	1437	957	B	C
1027	690	1284	880	1341	880	D	B
1111	760	1360	938	1399	938	C	A
929	633	1188	823	1207	823	D	A
1013	676	1245	842	1284	842	C	C
844	591	1092	765	1130	746	D	C
HIGH / LOW HEAT CFM							
TM(8,L)V060A12MP12C		TM(8,L)V080B12MP12C		TM(8,L)V080C16MP12C		Jumper Settings	
HIGH HEAT	LOW HEAT	HIGH HEAT	LOW HEAT	HIGH HEAT	LOW HEAT	HEAT Tap	ADJ Tap*
1111	963	1480	1284	1480	1289	A	Any
988	825	1317	1100	1317	1100	B	Any
889	722	1185	963	1185	960	C	Any
808	642	1077	856	1077	855	D	Any
TM(8,L)V100C16MP12C		TM(8,L)V100C20MP12C		TM(8,L)V120C20MP12C		Jumper Settings	
HIGH HEAT	LOW HEAT	HIGH HEAT	LOW HEAT	HIGH HEAT	LOW HEAT	HEAT Tap	ADJ Tap*
1851	1604	1851	1604	2220	1925	A	Any
1646	1375	1646	1375	1975	1651	B	Any
1481	1204	1481	1204	1778	1444	C	Any
1347	1070	1347	1070	1616	1284	D	Any

All CFM's are shown at 0.5" w.c. external static pressure. These units have variable speed motors that automatically adjust to provide constant CFM from 0.0" to 0.6" w.c. static pressure. From 0.6" to 1.0" static pressure, CFM is reduced by 2% per 0.1" increase in static. Operation on duct systems with greater than 1.0" w.c. external static pressure is not recommended.

NOTE: At some settings, LOW COOL and/or LOW HEAT airflow may be lower that what is required to operate an airflow switch on certain models of electronic air cleaners. Consult the instructions for the electronic air cleaner for further details.

* The ADJ "D" tap should not be used.