



## TECHNICAL GUIDE

### AFFINITY

### R-410A SPLIT-SYSTEM AIR CONDITIONERS

### 18 SEER

### MODELS: CZH024 THRU 060 (2 THRU 5 NOMINAL TONS)



Due to continuous product improvement, specifications are subject to change without notice.

Visit us on the web at [www.york.com](http://www.york.com) for the most up-to-date technical information.

Additional rating information can be found at [www.ariprimer.net.org](http://www.ariprimer.net.org).

## DESCRIPTION

The CZH Series condensing unit is the outdoor part of a versatile air conditioning system. It is designed to be custom matched with one of our complete line of evaporator sections, each designed to serve a specific function. Matching air handlers are available for upflow, downflow, and horizontal left or right application to provide a complete system. Electric heaters are available if required. Add-on coils are available for use with upflow, downflow, or horizontal furnaces. Field installed accessories are available as needed.

## WARRANTY

*5-year limited parts warranty.*

*10-year limited compressor warranty.*

*Premium System Warranty - Limited lifetime compressor and 10-year parts when matched with an approved York Affinity furnace or UPG air handler and coil.*

## FEATURES

- **Superior Coil Protection** – A stamped decorative metal coil guard completely protects coil from debris and other large damaging material while a polymer mesh further protects the coil against smaller particles.
- **Isolated Compressor Compartment** – A molded composite bulkhead isolates the compressor from the rest of the unit reducing sound and vibration.
- **Protected Compressors** – Each compressor is protected against abnormal pressures by an internal pressure relief valve and factory installed high and low pressure controls. Additional protection against moisture and debris is provided by factory installed liquid line filter driers.
- **Environmentally Friendly Refrigerant** – Next generation refrigerant R-410A delivers environmentally friendly performance with zero ozone depletion.
- **Durable Finish** – Automotive quality finish provides the ultimate protection from harmful U.V. rays and rust creep ensuring long-lasting high quality appearance. A powder-paint topcoat is applied over a baked-on primer, using a galvanized, zinc coated steel base material. The result is a finish that has been proven in testing to provide 33% greater durability than conventional powder-coat finishes.
- **Lower Installed Cost** – Designed to provide enhanced installability by featuring a slide-down control compartment and angled service valves to reduce overall installation time and cost.
- **Low Operating Sound Levels** – A fan design boasting technology adapted from aeronautic and defense engineering provides for whisper quiet operation by allowing airflow to flow smoothly and efficiently across the fan tips.
- **Filter-Drier** – A factory installed, solid core liquid line filter-drier filters harmful debris and moisture from the system.
- **Easy Service Access** – A full end, full service, access panel with handle makes for easy entry to internal components.
- **Composite Base** - Strong and durable composite base pan resists rust and corrosion while it helps reduce vibrations and noise.
- **Quiet drive system** - Features combination of swept-wing fan, composite base pan, isolated compressor compartment and two-stage compressor to reduce overall sound to a mere whisper.
- **Low RPM fan motor** - Helps to reduce airflow noise.

Certified in accordance with the Unitary Small Equipment certification program, which is based on ARI Standard 210/240.

**Physical and Electrical Data**

MODEL		CZH02411	CZH03611	CZH04811	CZH06011
Unit Supply Voltage		208-230V, 1 $\phi$ , 60Hz			
Normal Voltage Range <sup>1</sup>		187 to 252			
Minimum Circuit Ampacity		15.6	23.6	29.2	34.8
Max. Overcurrent Device Amps <sup>2</sup>		25	40	50	60
Min. Overcurrent Device Amps <sup>3</sup>		20	25	30	35
Multi-stage Compressor		Yes	Yes	Yes	Yes
Compressor Type		Scroll	Scroll	Scroll	Scroll
Compressor Amps	Rated Load	10.3	16.7	21.2	25.6
	Locked Rotor	52	82	96	118
Crankcase Heater		No	No	No	No
Fan Motor Amps	Rated Load	2.8	2.8	2.8	2.8
Fan Diameter Inches		24	24	24	24
Fan Motor	Rated HP	1/3	1/3	1/3	1/3
	Nominal RPM	685	685	685	685
	Nominal CFM	2900	3200	3100	3150
Coil	Face Area Sq. Ft.	23.58	23.58	23.58	23.58
	Rows Deep	2	2	2	2
	Fins / Inch	16	16	14	14
Liquid Line Set OD (Field Installed)		3/8	3/8	3/8	3/8
Vapor Line Set OD (Field Installed)		3/4	3/4	7/8	7/8
Unit Charge (Lbs. - Oz.) <sup>4</sup>		15 - 1	13 - 7	12 - 9	13 - 5
Charge Per Foot, Oz.		0.62	0.62	0.67	0.67
Operating Weight Lbs.		305	305	310	330

- 1 Rated in accordance with ARI Standard 110, utilization range "A".
- 2 Dual element fuses or HACR circuit breaker. Maximum allowable overcurrent protection.
- 3 Dual element fuses or HACR circuit breaker. Minimum recommended overcurrent protection.
- 4 The Unit Charge is correct for the outdoor unit, matched indoor coil and 15 feet of refrigerant tubing. For tubing lengths other than 15 feet, add or subtract the amount of refrigerant, using the difference in length multiplied by the per foot value.

All dimensions are in inches. They are subject to change without notice. Certified dimensions will be provided upon request.

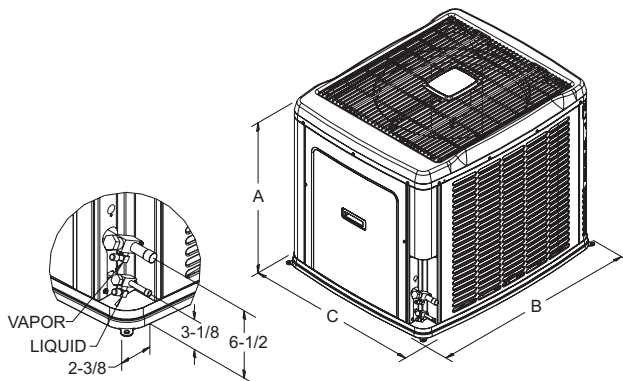

Unit Model	Dimensions (Inches)			Refrigerant Connection Service Valve Size	
	A	B	C	Liquid	Vapor
24	39-1/2	42	34	3/8"	3/4"
36	39-1/2	42	34		
48	39-1/2	42	34		7/8"
60	39-1/2	42	34		

<b>Additional R-410A Charge / TXV Size for Various Matched Systems</b>				
Outdoor Unit	CZH02411	CZH03611	CZH04811	CZH06011
Approved System Thermal Expansion Valve <sup>1</sup>	1TVM902	1TVM904	1TVM905	1TVM906
Factory R-410A Charge, lbs-oz	16 - 2	15 - 14	13 - 8	14 - 1
<b>Indoor Coil<sup>2</sup></b>	<b>TXV Kit<sup>3</sup> - Additional Charge, Oz</b>			
FC/MC/PC32A	1	-	-	-
FC/MC/PC35B	0	-	-	-
FC/MC/PC35C	0	-	-	-
FC/MC/PC37A	7	24	-	-
FC/MC/PC43B	7	24	-	-
FC/MC/PC43C	7	24	-	-
FC/MC/PC48C	17	7	10	-
FC/MC/PC48D	17	7	10	-
FC/PC60C	-	-	-	0
FC/MC/PC60D	-	-	-	0
FC/MC62D	-	39	15	12
HC36B	0	-	-	-
HC42C	-	24	-	-
HC60D	-	-	1	0
UC48D	17	7	10	-
UC60D	-	-	-	0
AV36C	7	0	-	-
AV/SV48D	-	-	1	-
AV/SV60D	-	-	0	0
F4FV060D	-	-	1	0

**FOOTNOTES:**

- 1 Systems matched with furnace or air handlers not equipped with blower-off delays may require blower Time Delay Kit 2FD06700224.
- 2 PC coils cannot be used in downflow or horizontal applications. FC coils cannot be used in horizontal applications.
- 3 A TXV kit must be used with these coils to obtain system performance.

**Note:** If a TXV is factory installed on the coil, it must be replaced with the listed TXV.

**PROCEDURES:**

1. Unit factory charge listed on the unit nameplate includes refrigerant for the condenser, the smallest evaporator and 15 feet of inter-connecting line tubing.
2. Verify the TXV and additional charge required for specific evaporator coil in the system using the above table.
3. Additional charge for the amount of interconnecting line tubing greater than 15 feet at the rate specified on the previous page.
4. Permanently mark the unit nameplate with the total system charge. Total System Charge = Base Charge (as shipped) + adder for evaporator + adder for line set.

## COOLING CAPACITY - With Air Handler Coils

UNIT MODEL	AIR HANDLER		COIL MODEL <sup>1</sup>	COOLING					
	MODEL	W		STAGE	RATED CFM	NET MBH	SEER	EER	
<b>1 PH 18 SEER AC WITH MV</b>									
CZH02411	MV12B	17	FC/MC/PC35B	1	620	18.2	13.8	17.05	14.50
				2	800	23.6	17.2		13.80
	MV12B	17	FC/MC/PC35C	1	620	18.2	13.8	17.05	14.50
				2	800	23.6	17.2		13.80
	MV12B	17	FC/MC/PC43B	1	620	18.5	14.0	17.20	14.65
				2	800	24.0	17.5		14.00
	MV12B	17	FC/MC/PC43C	1	620	18.5	14.0	17.20	14.65
				2	800	24.0	17.5		14.00
	MV12D	24	FC/MC/PC48D	1	645	18.9	14.3	18.00	15.25
				2	835	24.6	17.9		14.45
	MV12D	24	UC48D	1	645	18.9	14.3	18.00	15.25
				2	835	24.6	17.9		14.45
CZH03611	MV12B	17	FC/MC/PC43B	1	775	25.6	18.0	17.70	14.90
				2	1200	36.0	25.2		13.55
	MV12B	17	FC/MC/PC43C	1	775	25.6	18.0	17.70	14.90
				2	1200	36.0	25.2		13.55
	MV16C	21	FC/MC/PC43C	1	775	25.7	18.1	18.00	15.00
				2	1200	36.2	25.3		14.00
	MV12D	24	FC/MC/PC48D	1	735	25.6	18.0	18.40	15.40
				2	1135	36.0	25.2		13.95
	MV12D	24	UC48D	1	735	25.6	18.0	18.40	15.40
				2	1135	36.0	25.2		13.95
	MV16C	21	FC/MC/PC48C	1	775	25.9	18.2	18.40	15.40
				2	1200	36.4	25.4		14.15
	MV16C	21	FC/MC/PC48D	1	775	25.9	18.2	18.40	15.40
				2	1200	36.4	25.4		14.15
	MV16C	21	UC48D	1	775	25.9	18.2	18.40	15.40
				2	1200	36.4	25.4		14.15
	MV20D	24	FC/MC/PC48D	1	770	25.8	18.1	18.30	15.30
				2	1200	36.6	25.6		14.20
MV20D	24	UC48D	1	770	25.8	18.1	18.30	15.30	
			2	1200	36.6	25.6		14.20	
MV12D	24	FC/MC62D	1	735	25.7	18.1	18.50	15.40	
			2	1135	36.6	25.6		14.25	
MV20D	24	FC/MC62D	1	770	25.9	18.2	18.30	15.30	
			2	1200	37.0	25.9		14.35	
CZH04811	MV16C	21	FC/MC/PC48C	1	1000	34.0	25.1	17.30	14.20
				2	1600	46.0	35.1		12.45
	MV16C	21	FC/MC/PC48D	1	1000	34.0	25.1	17.30	14.20
				2	1600	46.0	35.1		12.45
	MV16C	21	UC48D	1	1000	34.0	25.1	17.30	14.20
				2	1600	46.0	35.1		12.45
	MV20D	24	FC/MC/PC48D	1	1020	34.0	25.1	17.00	14.00
				2	1600	46.0	35.1		12.35
	MV20D	24	UC48D	1	1020	34.0	25.1	17.00	14.00
				2	1600	46.0	35.1		12.35
MV20D	24	FC/MC62D	1	1020	34.1	25.2	17.00	14.05	
			2	1600	46.5	35.5		12.50	
CZH06011	MV20D	24	FC/MC/PC60D	1	1030	40.2	27.3	15.30	12.55
				2	1800	55.5	40.5		11.55
	MV20D	24	UC60D	1	1030	40.2	27.3	15.30	12.55
				2	1800	55.5	40.5		11.55
	MV20D	24	FC/MC62D	1	1030	42.1	28.6	16.00	13.20
				2	1800	58.0	42.3		12.00

For notes see Page 5.

**COOLING CAPACITY - With Air Handler Coils (Continued)**

UNIT MODEL	AIR HANDLER		COIL MODEL <sup>1</sup>	COOLING					
	MODEL	W		STAGE	RATED CFM	NET MBH		SEER	EER
<b>1 PH 18 SEER AC WITH AV/SV</b>									
CZH02411	AV36C	21	N / A	1	600	18.4	13.9	17.60	14.95
				2	765	23.8	17.3		14.10
CZH03611	AV36C	21	N / A	1	830	25.7	18.1	18.00	15.25
				2	1270	35.6	24.9		13.45
CZH04811	AV/SV48D	24	N / A	1	1135	33.1	24.4	16.60	13.60
				2	1610	44.5	34.0		12.10
	AV/SV60D	24	N / A	1	1085	33.0	24.4	16.50	13.60
				2	1655	44.5	34.0		12.10
CZH06011	AV/SV60D	24	N / A	1	1145	41.5	28.2	15.70	13.00
				2	1765	55.5	40.5		11.65
<b>1 PH 18 SEER AC WITH F*F*</b>									
CZH04811	F4FV060	24	N / A	1	1200	33.6	24.8	16.85	13.75
				2	1600	44.5	34.0		12.15
CZH06011	F4FV060	24	N / A	1	1200	41.8	28.4	15.55	12.80
				2	1780	55.5	40.5		11.60
<p>Rated in accordance with DOE test procedures (Federal Register 12-27-79 and 3-18-88) and ARI Standards 210.  Cooling MBH based on 80°F entering air temperature, 50% RH, and rated air flow.  EER (Energy Efficiency Ratio) is the total cooling output in BTU's at 95°F outdoor ambient divided by the total electric power in watt-hours at those conditions.  SEER (Seasonal Energy Efficiency Ratio) is the total cooling output in BTU's during a normal annual usage period for cooling divided by the total electric power input in watt-hours during the same period.</p>									

1 MC coils available with a factory installed horizontal drain pan. See price pages for specific model number.

**COOLING CAPACITY - With Variable Speed Furnaces**

UNIT MODEL	VARIABLE SPEED FURNACE MODEL	COIL MODEL <sup>1</sup>	W	COOLING					
				STAGE	RATED CFM	NET MBH		SEER	EER
						TOTAL	SENSIBLE		
<b>1 PH 18 SEER AC WITH VARIABLE SPEED FURNACES</b>									
CZH02411	PV8*A12	14	FC/MC/PC32A	1	470	17.2	13.0	16.70	14.15
				2	750	23.2	16.9		13.55
	PV9*A12	14	FC/MC/PC32A	1	625	18.1	13.7	16.60	14.25
				2	800	23.2	16.9		13.05
	P(C,V)9*B12	17	FC/MC/PC35B	1	560	17.9	13.6	17.05	14.55
				2	820	23.4	17.0		13.45
	P(C,V)9*B12	17	FC/MC/PC35C	1	560	17.9	13.6	17.05	14.55
				2	820	23.4	17.0		13.45
	PV8*A12	14	FC/MC/PC37A	1	470	17.4	13.2	17.00	14.35
				2	750	23.6	17.2		13.75
	PV9*A12	14	FC/MC/PC37A	1	625	18.6	14.1	17.00	14.60
				2	800	23.6	17.2		13.30
	P(C,V)9*B12	17	FC/MC/PC43B	1	560	18.1	13.7	17.35	14.70
				2	820	24.0	17.5		13.70
	P(C,V)9*B12	17	FC/MC/PC43C	1	560	18.1	13.7	17.35	14.70
				2	820	24.0	17.5		13.70
	P(C,V)9*B12	17	HC36B	1	560	17.9	13.6	17.10	14.55
				2	820	23.4	17.0		13.55

For notes see Page 8.

## COOLING CAPACITY - With Variable Speed Furnaces (Continued)

UNIT MODEL	VARIABLE SPEED FURNACE MODEL	COIL MODEL <sup>1</sup>	W	COOLING					
				STAGE	RATED CFM	NET MBH		SEER	EER
						TOTAL	SENSIBLE		
CZH03611	PV8*A12	14	FC/MC/PC37A	1	750	25.4	17.9	17.50	14.80
				2	1185	35.8	25.0		13.25
	PV9*A12	14	FC/MC/PC37A	1	780	25.6	18.0	17.50	14.75
				2	1200	35.6	24.9		13.00
	PV8*B16	17	FC/MC/PC43B	1	750	25.4	17.9	17.80	14.90
				2	1200	36.0	25.2		13.70
	PV8*B16	17	FC/MC/PC43C	1	750	25.4	17.9	17.80	14.90
				2	1200	36.0	25.2		13.70
	PV8*C16	21	FC/MC/PC43C	1	640	24.6	17.3	17.70	14.80
				2	1200	36.2	25.3		13.80
	PV8*C20	21	FC/MC/PC43C	1	780	25.7	18.1	17.90	15.10
				2	1200	36.0	25.2		13.50
	P(C,V)9*B12	17	FC/MC/PC43B	1	770	25.6	18.0	17.60	14.85
				2	1185	35.6	24.9		13.25
	P(C,V)9*B12	17	FC/MC/PC43C	1	770	25.6	18.0	17.60	14.85
				2	1185	35.6	24.9		13.25
	P(C,V)9*C16	21	FC/MC/PC43C	1	770	25.7	18.1	18.00	15.30
				2	1175	35.8	25.0		13.60
	P(C,V)9*C20	21	FC/MC/PC43C	1	790	25.8	18.1	17.90	15.05
				2	1195	36.0	25.2		13.65
	PV8*C16	21	FC/MC/PC48C	1	640	24.7	17.4	18.20	15.15
				2	1200	36.4	25.4		14.00
	PV8*C16	21	FC/MC/PC48D	1	640	24.7	17.4	18.20	15.15
				2	1200	36.4	25.4		14.00
	PV8*C16	21	UC48D	1	640	24.7	17.4	18.20	15.15
				2	1200	36.4	25.4		14.00
	PV8*C20	21	FC/MC/PC48C	1	780	25.9	18.2	18.35	15.45
				2	1200	36.2	25.3		13.55
	PV8*C20	21	FC/MC/PC48D	1	780	25.9	18.2	18.35	15.45
				2	1200	36.2	25.3		13.55
	PV8*C20	21	UC48D	1	780	25.9	18.2	18.35	15.45
				2	1200	36.2	25.3		13.55
	P(C,V)9*C16	21	FC/MC/PC48C	1	770	25.9	18.2	18.40	15.60
				2	1175	36.2	25.3		13.80
	P(C,V)9*C16	21	FC/MC/PC48D	1	770	25.9	18.2	18.40	15.60
				2	1175	36.2	25.3		13.80
	P(C,V)9*C16	21	UC48D	1	770	25.9	18.2	18.40	15.60
				2	1175	36.2	25.3		13.80
	P(C,V)9*C20	21	FC/MC/PC48C	1	790	25.9	18.2	18.20	15.25
				2	1195	36.2	25.3		13.75
P(C,V)9*C20	21	FC/MC/PC48D	1	790	25.9	18.2	18.20	15.25	
			2	1195	36.2	25.3		13.75	
P(C,V)9*C20	21	UC48D	1	790	25.9	18.2	18.20	15.25	
			2	1195	36.2	25.3		13.75	
P(C,V)9*D20	24	FC/MC/PC48D	1	775	25.9	18.2	18.30	15.40	
			2	1220	36.4	25.4		13.90	
P(C,V)9*D20	24	UC48D	1	775	25.9	18.2	18.30	15.40	
			2	1220	36.4	25.4		13.90	
PV8*C20	21	FC/MC62D	1	780	26.0	18.3	18.35	15.40	
			2	1200	36.6	25.6		13.70	
P(C,V)9*C20	21	FC/MC62D	1	790	26.0	18.3	18.20	15.25	
			2	1195	36.6	25.6		13.90	

For notes see Page 8.

## COOLING CAPACITY - With Variable Speed Furnaces (Continued)

UNIT MODEL	VARIABLE SPEED FURNACE MODEL	COIL MODEL <sup>1</sup>	W	COOLING					
				STAGE	RATED CFM	NET MBH		SEER	EER
						TOTAL	SENSIBLE		
CZH03611	P(C,V)9*D20	24	FC/MC62D	1	775	26.0	18.3	18.25	15.30
				2	1220	36.8	25.7		14.05
	PV8*C16	21	HC42C	1	640	24.6	17.3	17.80	14.85
				2	1200	36.2	25.3		13.85
	PV8*C20	21	HC42C	1	780	25.7	18.1	18.05	15.20
				2	1200	36.0	25.2		13.50
	P(C,V)9*C16	21	HC42C	1	770	25.6	18.0	18.25	15.25
				2	1175	36.0	25.2		13.75
	P(C,V)9*C20	21	HC42C	1	790	25.8	18.1	17.90	15.05
				2	1195	36.0	25.2		13.65
CZH04811	PV8*C16	21	FC/MC/PC48C	1	880	33.0	24.4	16.90	13.90
				2	1500	45.0	34.4		11.95
	PV8*C16	21	FC/MC/PC48D	1	880	33.0	24.4	16.90	13.90
				2	1500	45.0	34.4		11.95
	PV8*C16	21	UC48D	1	880	33.0	24.4	16.90	13.90
				2	1500	45.0	34.4		11.95
	PV8*C20	21	FC/MC/PC48C	1	1030	34.1	25.2	17.10	14.15
				2	1610	45.5	34.8		12.05
	PV8*C20	21	FC/MC/PC48D	1	1030	34.1	25.2	17.10	14.15
				2	1610	45.5	34.8		12.05
	PV8*C20	21	UC48D	1	1030	34.1	25.2	17.10	14.15
				2	1610	45.5	34.8		12.05
	P(C,V)9*C16	21	FC/MC/PC48C	1	1090	34.6	25.6	17.50	14.50
				2	1600	45.5	34.8		11.85
	P(C,V)9*C16	21	FC/MC/PC48D	1	1090	34.6	25.6	17.50	14.50
				2	1600	45.5	34.8		11.85
	P(C,V)9*C16	21	UC48D	1	1090	34.6	25.6	17.50	14.50
				2	1600	45.5	34.8		11.85
	P(C,V)9*C20	21	FC/MC/PC48C	1	1010	33.9	25.0	16.90	13.95
				2	1580	45.5	34.8		12.05
	P(C,V)9*C20	21	FC/MC/PC48D	1	1010	33.9	25.0	16.90	13.95
				2	1580	45.5	34.8		12.05
	P(C,V)9*C20	21	UC48D	1	1010	33.9	25.0	16.90	13.95
				2	1580	45.5	34.8		12.05
	P(C,V)9*D20	24	FC/MC/PC48D	1	985	33.8	25.0	16.95	13.95
				2	1560	45.5	34.8		12.20
	P(C,V)9*D20	24	UC48D	1	985	33.8	25.0	16.95	13.95
				2	1560	45.5	34.8		12.20
	PV8*C20	21	FC/MC62D	1	1030	34.2	25.3	17.20	14.25
				2	1610	46.0	35.1		12.20
P(C,V)9*C20	21	FC/MC62D	1	1010	34.1	25.2	16.80	14.00	
			2	1580	46.0	35.1		12.15	
P(C,V)9*D20	24	FC/MC62D	1	985	33.9	25.0	17.00	14.00	
			2	1560	46.0	35.1		12.30	
P(C,V)9*D20	24	HC60D	1	985	32.3	23.9	16.25	13.25	
			2	1560	44.0	33.6		11.85	

For notes see Page 8.

**COOLING CAPACITY - With Variable Speed Furnaces (Continued)**

UNIT MODEL	VARIABLE SPEED FURNACE MODEL	COIL MODEL <sup>1</sup>	W	COOLING					
				STAGE	RATED CFM	NET MBH		SEER	EER
						TOTAL	SENSIBLE		
CZH06011	PV8*C20	21	FC/PC60C	1	1120	41.0	27.8	15.45	12.75
				2	1730	55.0	40.1		11.40
	PV8*C20	21	FC/MC/PC60D	1	1120	41.0	27.8	15.45	12.75
				2	1730	55.0	40.1		11.40
	PV8*C20	21	UC60D	1	1120	41.0	27.8	15.45	12.75
				2	1730	55.0	40.1		11.40
	P(C,V)9*C20	21	FC/PC60C	1	1075	40.4	27.4	15.25	12.55
				2	1650	54.0	39.4		11.25
	P(C,V)9*C20	21	FC/MC/PC60D	1	1075	40.4	27.4	15.25	12.55
				2	1650	54.0	39.4		11.25
	P(C,V)9*C20	21	UC60D	1	1075	40.4	27.4	15.25	12.55
				2	1650	54.0	39.4		11.25
	P(C,V)9*D20	24	FC/MC/PC60D	1	1020	40.2	27.3	15.25	12.55
				2	1620	54.0	39.4		11.45
	P(C,V)9*D20	24	UC60D	1	1020	40.2	27.3	15.25	12.55
				2	1620	54.0	39.4		11.45
	PV8*C20	21	FC/MC62D	1	1120	42.8	29.1	16.10	13.35
				2	1730	57.0	41.6		11.70
	P(C,V)9*C20	21	FC/MC62D	1	1075	42.4	28.8	15.95	13.25
				2	1650	56.5	41.2		11.65
P(C,V)9*D20	24	FC/MC62D	1	1020	42.0	28.5	15.90	13.20	
			2	1620	56.5	41.2		11.80	
P(C,V)9*D20	24	HC60D	1	1020	40.1	27.2	15.30	12.55	
			2	1620	54.5	39.7		11.50	

1 MC coils available with a factory installed horizontal drain pan.

**ACCESSORIES\***

**Hard Start Kit (024-31994-000, 024-31995-000)** - Provides increased starting torque for areas with low voltage.

**TXV Kits** - 1TVM9 series thermal expansion valves precisely meter refrigerant for optimum performance

**Dehumidistat (2HU16700124)** - Provides increased dehumidification when matched with variable speed furnace or air handler.

**Room Thermostats** - A wide selection of compatible thermostats are available to provide optimum performance and features for any installation.

1 Heat Stage only, manual, mechanical thermostat. Add sub-base for 3H/2C.

3H/2C, manual changeover electronic non-programmable thermostat.

3H/2C, auto/manual changeover, electronic programmable, deluxe 7-day, thermostat.

3H/2C, auto/manual changeover, electronic programmable.

\* For the most current accessory information, refer to the price book or consult factory.

**SOUND POWER RATINGS\***

UNIT MODEL	(dBA)
024	71
036	73
048	72
060	74

\* Rated in accordance with ARI 270-95 Standards.

**COLOR GRILLES**

CHOICE OF SEVERAL COLOR COIL GRILLES TO COMPLIMENT ANY HOME.		
Color Grill	Color Description	
1CP1136	Terra Cotta	All
1CP0236	Jet Black	All
1CP0336	Stone	All
1CP0436	Bermuda	All
1CP0536	Gunmetal	All
1CP0636	Chocolate	All



COOLING PERFORMANCE DATA - LOW CFM 1-STAGE OPERATION																
OUTDOOR UNIT MODEL NO.		CZH02411														
INDOOR COIL MODEL NO.		FC48D + MV12D														
CONDENSER ENTERING AIR TEMPERATURE	ID CFM	550					600					650				
	ID DB (°F)	80	80	75	80	80	80	80	75	80	80	80	80	75	80	80
	ID WB (°F)	57	62	62	67	72	57	62	62	67	72	57	62	62	67	72
65	T.C.	18.6	19.9	18.9	21.7	23.9	19.0	19.9	19.1	21.8	24.4	19.4	20.0	19.3	22.0	24.9
	S.C.	18.6	17.5	14.9	14.8	11.7	19.2	18.5	15.6	15.5	12.1	19.7	19.4	16.2	16.2	12.5
	K.W.	0.76	0.75	0.76	0.74	0.74	0.75	0.75	0.75	0.73	0.74	0.75	0.75	0.75	0.73	0.74
75	T.C.	17.8	18.8	18.0	20.6	22.8	18.3	18.9	18.3	20.9	23.2	18.7	19.1	18.5	21.1	23.6
	S.C.	17.9	17.1	14.5	14.4	11.3	18.4	17.9	15.1	15.1	11.8	18.9	18.6	15.8	15.9	12.2
	K.W.	0.93	0.92	0.93	0.91	0.90	0.92	0.92	0.92	0.90	0.90	0.91	0.91	0.92	0.90	0.90
85	T.C.	17.1	17.6	17.1	19.5	21.6	17.5	17.9	17.4	19.9	22.0	17.9	18.2	17.7	20.2	22.3
	S.C.	17.2	16.8	14.0	14.0	10.9	17.7	17.3	14.7	14.8	11.4	18.1	17.9	15.4	15.5	11.9
	K.W.	1.09	1.09	1.09	1.08	1.06	1.08	1.08	1.09	1.07	1.06	1.07	1.08	1.08	1.06	1.05
95	T.C.	16.4	16.5	16.2	18.5	20.5	16.8	16.9	16.6	18.9	20.8	17.1	17.2	16.9	19.4	21.0
	S.C.	16.5	16.4	13.6	13.7	10.5	17.0	16.8	14.3	14.4	11.1	17.4	17.2	15.0	15.1	11.7
	K.W.	1.26	1.26	1.26	1.24	1.22	1.24	1.25	1.25	1.24	1.22	1.24	1.24	1.25	1.23	1.21
105	T.C.	15.3	15.4	14.9	17.0	19.0	15.7	15.8	15.2	17.3	19.1	16.0	16.2	15.5	17.7	19.3
	S.C.	15.4	15.2	13.0	13.2	10.1	15.8	15.6	13.6	13.9	10.5	16.2	16.0	14.3	14.5	11.0
	K.W.	1.48	1.49	1.49	1.47	1.45	1.47	1.48	1.48	1.47	1.45	1.46	1.47	1.48	1.46	1.45
115	T.C.	14.2	14.3	13.6	15.5	17.5	14.6	14.7	13.9	15.8	17.6	15.0	15.1	14.1	16.1	17.7
	S.C.	14.4	14.1	12.4	12.8	9.6	14.7	14.5	13.0	13.4	10.0	15.1	14.9	13.5	13.9	10.4
	K.W.	1.70	1.71	1.71	1.70	1.68	1.69	1.70	1.70	1.69	1.67	1.68	1.69	1.70	1.68	1.67
125	T.C.	13.1	13.2	12.3	14.0	15.9	13.5	13.6	12.5	14.3	16.0	13.9	14.0	12.7	14.5	16.1
	S.C.	13.3	13.0	11.8	12.3	9.2	13.6	13.4	12.3	12.9	9.5	14.0	13.8	12.8	13.4	9.7
	K.W.	1.92	1.93	1.93	1.92	1.91	1.91	1.92	1.93	1.91	1.90	1.91	1.91	1.92	1.91	1.90

NOTE: ALL CAPACITIES ARE NET (KBTUH) WITH INDOOR FAN HEAT ALREADY DEDUCTED AT 1250 BTUH/1000 CFM.

### Multipliers for determining the performance with other indoor sections.

NOTE: For dry bulb temperatures different than those listed (between 73-87 F), sensible capacity increases by 1060 BTUH per 1000 CFM per degree above the listed temperature and decreases by 1060 BTUH per 1000 CFM per degree below the listed temperature.

NOTE: KW RATING IS FOR OUTDOOR AND INDOOR UNITS.

### LOW CFM

Air Handler	Coil	T.C.	S.C.	KW
AV36C	-	0.97	0.97	0.99
MV12B	FC/MC/PC35B	0.96	0.97	1.01
MV12B	FC/MC/PC35C	0.96	0.97	1.01
MV12B	FC/MC/PC35B	0.98	0.98	1.02
MV12B	FC/MC/PC35C	0.98	0.98	1.02
MV12D	FC/MC/PC48D	1.00	1.00	1.00
MV12D	UC48D	1.00	1.00	1.00

Variable Speed Furnace	Coil	T.C.	S.C.	KW
PV8*A12	FC/MC/PC32A	0.91	0.91	0.98
PV9*A12	FC/MC/PC32A	0.96	0.96	1.02
P(C,V)9*B12	FC/MC/PC35B	0.95	0.95	0.99
P(C,V)9*B12	FC/MC/PC35C	0.95	0.95	0.99
PV8*A12	FC/MC/PC37A	0.92	0.92	0.98
PV9*A12	FC/MC/PC37A	0.98	0.99	1.03
P(C,V)9*B12	FC/MC/PC43B	0.96	0.96	0.99
P(C,V)9*B12	FC/MC/PC43C	0.96	0.96	0.99
P(C,V)9*B12	HC36B	0.95	0.95	0.99

<b>COOLING PERFORMANCE DATA - HIGH CFM 2-STAGE OPERATION</b>																
<b>OUTDOOR UNIT MODEL NO.</b>		<b>CZH02411</b>														
<b>INDOOR COIL MODEL NO.</b>		<b>FC48D + MV12D</b>														
<b>CONDENSER ENTERING AIR TEMPERATURE</b>	<b>ID CFM</b>	<b>700</b>					<b>800</b>					<b>900</b>				
	<b>ID DB (°F)</b>	80	80	75	80	80	80	80	75	80	80	80	80	75	80	80
	<b>ID WB (°F)</b>	57	62	62	67	72	57	62	62	67	72	57	62	62	67	72
65	T.C.	23.1	25.7	25.0	28.6	30.7	24.3	26.0	26.1	28.8	31.1	25.5	26.3	27.1	28.9	31.6
	S.C.	22.6	21.4	17.9	18.3	14.5	23.8	23.1	19.5	19.1	15.3	25.0	24.8	21.0	20.0	16.1
	K.W.	1.12	1.14	1.14	1.16	1.17	1.13	1.14	1.14	1.16	1.18	1.15	1.15	1.15	1.17	1.19
75	T.C.	22.5	24.3	23.9	27.1	29.2	23.5	24.7	24.7	27.4	29.7	24.5	25.1	25.5	27.6	30.1
	S.C.	21.9	20.9	17.5	17.8	14.0	23.0	22.4	18.9	18.7	14.8	24.0	23.8	20.3	19.7	15.5
	K.W.	1.31	1.32	1.32	1.34	1.35	1.31	1.32	1.32	1.34	1.36	1.33	1.33	1.33	1.35	1.37
85	T.C.	21.8	22.9	22.8	25.6	27.7	22.6	23.4	23.4	26.0	28.2	23.4	23.8	23.9	26.4	28.7
	S.C.	21.3	20.4	17.2	17.3	13.6	22.1	21.6	18.4	18.4	14.3	22.9	22.7	19.6	19.4	15.0
	K.W.	1.49	1.50	1.50	1.52	1.53	1.49	1.50	1.50	1.52	1.54	1.51	1.51	1.51	1.54	1.55
95	T.C.	21.2	21.5	21.8	24.0	26.2	21.8	22.1	22.1	24.6	26.7	22.4	22.5	22.3	25.2	27.2
	S.C.	20.6	20.0	16.8	16.8	13.1	21.3	20.9	17.9	18.0	13.7	21.9	21.7	18.9	19.1	14.4
	K.W.	1.67	1.68	1.67	1.70	1.72	1.67	1.68	1.68	1.70	1.72	1.69	1.69	1.69	1.72	1.73
105	T.C.	20.1	20.3	20.4	22.6	24.5	20.6	20.9	20.7	23.0	25.0	21.2	21.4	20.9	23.5	25.5
	S.C.	19.5	19.0	16.2	16.3	12.6	20.1	19.8	17.2	17.3	13.2	20.7	20.5	18.2	18.4	13.8
	K.W.	1.93	1.93	1.93	1.95	1.97	1.93	1.94	1.93	1.96	1.98	1.95	1.95	1.94	1.97	1.99
115	T.C.	19.0	19.2	19.1	21.2	22.9	19.5	19.7	19.3	21.5	23.4	20.0	20.2	19.5	21.8	23.9
	S.C.	18.5	18.1	15.5	15.8	12.0	19.0	18.8	16.6	16.7	12.6	19.6	19.4	17.6	17.6	13.2
	K.W.	2.17	2.18	2.17	2.20	2.23	2.18	2.18	2.18	2.21	2.23	2.20	2.20	2.19	2.22	2.24
125	T.C.	17.9	18.0	17.7	19.8	21.3	18.4	18.5	17.9	20.0	21.8	18.9	19.1	18.1	20.2	22.2
	S.C.	17.4	17.2	14.9	15.3	11.5	17.9	17.8	15.9	16.1	12.1	18.4	18.3	16.9	16.9	12.6
	K.W.	2.42	2.42	2.42	2.45	2.48	2.43	2.43	2.42	2.45	2.48	2.45	2.45	2.44	2.47	2.50

NOTE: ALL CAPACITIES ARE NET (KBTUH) WITH INDOOR FAN HEAT ALREADY DEDUCTED AT 1250 BTUH/1000 CFM.

### Multipliers for determining the performance with other indoor sections.

NOTE: For dry bulb temperatures different than those listed (between 73-87 F), sensible capacity increases by 1060 BTUH per 1000 CFM per degree above the listed temperature and decreases by 1060 BTUH per 1000 CFM per degree below the listed temperature.

NOTE: KW RATING IS FOR OUTDOOR AND INDOOR UNITS.

### HIGH CFM

Air Handler	Coil	T.C.	S.C.	KW
AV36C	-	0.97	0.97	0.99
MV12B	FC/MC/PC35B	0.96	0.96	1.00
MV12B	FC/MC/PC35C	0.96	0.96	1.00
MV12B	FC/MC/PC35B	0.98	0.98	1.01
MV12B	FC/MC/PC35C	0.98	0.98	1.01
MV12D	FC/MC/PC48D	1.00	1.00	1.00
MV12D	UC48D	1.00	1.00	1.00

Variable Speed Furnace	Coil	T.C.	S.C.	KW
PV8*A12	FC/MC/PC32A	0.94	0.94	1.01
PV9*A12	FC/MC/PC32A	0.94	0.94	1.04
P(C,V)9*B12	FC/MC/PC35B	0.95	0.95	1.02
P(C,V)9*B12	FC/MC/PC35C	0.95	0.95	1.02
PV8*A12	FC/MC/PC37A	0.96	0.96	1.01
PV9*A12	FC/MC/PC37A	0.96	0.96	1.04
P(C,V)9*B12	FC/MC/PC43B	0.98	0.98	1.03
P(C,V)9*B12	FC/MC/PC43C	0.98	0.98	1.03
P(C,V)9*B12	HC36B	0.95	0.95	1.01

<b>COOLING PERFORMANCE DATA - LOW CFM 1-STAGE OPERATION</b>																
<b>OUTDOOR UNIT MODEL NO.</b>		<b>CZH03611</b>														
<b>INDOOR COIL MODEL NO.</b>		<b>FC62D + MV12D</b>														
<b>CONDENSER ENTERING AIR TEMPERATURE</b>	<b>ID CFM</b>	<b>750</b>					<b>800</b>					<b>850</b>				
	<b>ID DB (°F)</b>	80	80	75	80	80	80	80	75	80	80	80	80	75	80	80
	<b>ID WB (°F)</b>	57	62	62	67	72	57	62	62	67	72	57	62	62	67	72
65	T.C.	25.4	26.8	27.2	29.7	32.8	25.9	27.0	27.3	30.1	33.0	26.4	27.2	27.5	30.4	33.2
	S.C.	25.0	22.9	19.4	19.3	15.3	25.6	23.7	19.9	19.8	15.7	26.1	24.6	20.4	20.2	16.1
	K.W.	1.00	0.99	0.99	0.96	0.93	0.99	0.98	0.98	0.95	0.92	0.97	0.97	0.97	0.94	0.91
75	T.C.	24.3	25.5	25.7	28.3	31.2	24.9	25.7	25.9	28.6	31.3	25.4	26.0	26.1	28.9	31.5
	S.C.	24.0	22.3	18.8	18.7	14.8	24.6	23.1	19.4	19.2	15.3	25.1	23.8	19.9	19.7	15.7
	K.W.	1.24	1.23	1.23	1.20	1.17	1.22	1.22	1.22	1.19	1.16	1.21	1.21	1.21	1.18	1.16
85	T.C.	23.3	24.2	24.3	26.9	29.5	23.8	24.5	24.5	27.2	29.7	24.3	24.7	24.8	27.5	29.8
	S.C.	23.0	21.8	18.3	18.2	14.4	23.6	22.4	18.8	18.7	14.9	24.1	23.0	19.3	19.2	15.3
	K.W.	1.47	1.47	1.47	1.44	1.41	1.46	1.46	1.46	1.43	1.41	1.45	1.45	1.45	1.42	1.40
95	T.C.	22.2	22.9	22.8	25.4	27.9	22.7	23.2	23.1	25.8	28.0	23.3	23.5	23.4	26.1	28.2
	S.C.	22.0	21.2	17.7	17.6	14.0	22.6	21.7	18.2	18.2	14.5	23.1	22.2	18.8	18.7	14.9
	K.W.	1.71	1.71	1.71	1.68	1.65	1.70	1.70	1.70	1.67	1.65	1.69	1.69	1.69	1.66	1.64
105	T.C.	20.8	21.3	21.0	23.6	26.0	21.3	21.7	21.3	23.8	26.1	21.9	22.1	21.5	24.1	26.2
	S.C.	20.6	20.0	16.8	16.8	13.4	21.2	20.5	17.4	17.4	13.7	21.7	21.0	17.9	17.9	14.1
	K.W.	2.03	2.03	2.03	2.01	1.98	2.02	2.02	2.02	2.00	1.97	2.00	2.01	2.01	1.99	1.97
115	T.C.	19.4	19.7	19.3	21.7	24.1	20.0	20.2	19.5	22.0	24.2	20.5	20.7	19.7	22.2	24.3
	S.C.	19.2	18.8	16.0	16.1	12.8	19.8	19.3	16.6	16.6	13.0	20.4	19.8	17.1	17.1	13.3
	K.W.	2.34	2.33	2.34	2.32	2.30	2.33	2.33	2.33	2.31	2.29	2.31	2.32	2.32	2.30	2.28
125	T.C.	18.0	18.2	17.5	19.9	22.2	18.6	18.8	17.7	20.1	22.3	19.1	19.3	18.0	20.4	22.4
	S.C.	17.8	17.6	15.2	15.3	12.2	18.4	18.1	15.8	15.8	12.3	19.0	18.5	16.4	16.3	12.5
	K.W.	2.65	2.64	2.65	2.63	2.62	2.64	2.64	2.65	2.63	2.61	2.62	2.63	2.64	2.62	2.60

NOTE: ALL CAPACITIES ARE NET (KBTUH) WITH INDOOR FAN HEAT ALREADY DEDUCTED AT 1250 BTUH/1000 CFM.

### Multipliers for determining the performance with other indoor sections.

NOTE: For dry bulb temperatures different than those listed (between 73-87 F), sensible capacity increases by 1060 BTUH per 1000 CFM per degree above the listed temperature and decreases by 1060 BTUH per 1000 CFM per degree below the listed temperature.

NOTE: KW RATING IS FOR OUTDOOR AND INDOOR UNITS.

### LOW CFM

<b>Air Handler</b>	<b>Coil</b>	<b>T.C.</b>	<b>S.C.</b>	<b>KW</b>
AV36C	-	1.00	1.00	1.01
MV12B	FC/MC/PC43B	1.00	0.99	1.03
MV12B	FC/MC/PC43C	1.00	0.99	1.03
MV16C	FC/MC/PC43C	1.00	1.00	1.03
MV12D	FC/MC/PC48D	1.00	0.99	1.00
MV12D	UC48D	1.00	0.99	1.00
MV16C	FC/MC/PC48C	1.01	1.01	1.01
MV16C	FC/MC/PC48D	1.01	1.01	1.01
MV16C	UC48D	1.01	1.01	1.01
MV20D	FC/MC/PC48D	1.00	1.00	1.01
MV20D	UC48D	1.00	1.00	1.01
MV12D	FC/MC62D	1.00	1.00	1.00
MV20D	FC/MC62D	1.01	1.01	1.01

<b>Variable Speed Furnace</b>	<b>Coil</b>	<b>T.C.</b>	<b>S.C.</b>	<b>KW</b>
PV8*A12	FC/MC/PC37A	0.99	0.99	1.03
PV9*A12	FC/MC/PC37A	1.00	0.99	1.04
PV8*B16	FC/MC/PC43B	0.99	0.99	1.02
PV8*B16	FC/MC/PC43C	0.99	0.99	1.02
PV8*C16	FC/MC/PC43C	0.96	0.96	1.00
PV8*C20	FC/MC/PC43C	1.00	1.00	1.02
P(C,V)9*B12	FC/MC/PC43B	1.00	0.99	1.03
P(C,V)9*B12	FC/MC/PC43C	1.00	0.99	1.03

<b>Variable Speed Furnace</b>	<b>Coil</b>	<b>T.C.</b>	<b>S.C.</b>	<b>KW</b>
P(C,V)9*C16	FC/MC/PC43C	1.00	1.00	1.01
P(C,V)9*C20	FC/MC/PC43C	1.00	1.00	1.03
PV8*C16	FC/MC/PC48C	0.96	0.96	0.98
PV8*C16	FC/MC/PC48D	0.96	0.96	0.98
PV8*C16	UC48D	0.96	0.96	0.98
PV8*C20	FC/MC/PC48C	1.01	1.01	1.00
PV8*C20	FC/MC/PC48D	1.01	1.01	1.00
PV8*C20	UC48D	1.01	1.01	1.00
P(C,V)9*C16	FC/MC/PC48C	1.01	1.01	0.99
P(C,V)9*C16	FC/MC/PC48D	1.01	1.01	0.99
P(C,V)9*C16	UC48D	1.01	1.01	0.99
P(C,V)9*C20	FC/MC/PC48C	1.01	1.01	1.02
P(C,V)9*C20	FC/MC/PC48D	1.01	1.01	1.02
P(C,V)9*C20	UC48D	1.01	1.01	1.02
P(C,V)9*D20	FC/MC/PC48D	1.01	1.01	1.01
P(C,V)9*D20	UC48D	1.01	1.01	1.01
PV8*C20	FC/MC62D	1.01	1.01	1.01
P(C,V)9*C20	FC/MC62D	1.01	1.01	1.02
P(C,V)9*D20	FC/MC62D	1.01	1.01	1.02
PV8*C16	HC42C	0.96	0.96	0.99
PV8*C20	HC42C	1.00	1.00	1.01
P(C,V)9*C16	HC42C	1.00	0.99	1.01
P(C,V)9*C20	HC42C	1.00	1.00	1.03

<b>COOLING PERFORMANCE DATA - HIGH CFM 2-STAGE OPERATION</b>																
<b>OUTDOOR UNIT MODEL NO.</b>		<b>CZH03611</b>														
<b>INDOOR COIL MODEL NO.</b>		<b>FC62D + MV12D</b>														
<b>CONDENSER ENTERING AIR TEMPERATURE</b>	ID CFM	1100					1200					1300				
	ID DB (°F)	80	80	75	80	80	80	80	75	80	80	80	80	75	80	80
	ID WB (°F)	57	62	62	67	72	57	62	62	67	72	57	62	62	67	72
65	T.C.	35.7	38.1	38.5	41.2	45.8	37.2	39.1	38.8	41.7	46.1	38.6	40.1	39.1	42.1	46.3
	S.C.	34.5	31.9	27.3	26.9	21.2	36.1	33.4	28.6	27.7	22.1	37.5	35.0	29.9	28.4	22.9
	K.W.	1.71	1.74	1.74	1.79	1.82	1.74	1.76	1.76	1.81	1.84	1.78	1.79	1.78	1.84	1.86
75	T.C.	34.6	36.5	36.7	39.5	43.6	35.9	37.4	37.1	40.0	43.9	37.1	38.2	37.5	40.4	44.2
	S.C.	33.6	31.1	26.5	26.0	20.6	34.8	32.6	27.6	27.0	21.4	36.0	34.1	28.8	27.9	22.1
	K.W.	1.98	2.00	2.00	2.05	2.07	2.00	2.02	2.01	2.06	2.09	2.04	2.05	2.04	2.09	2.12
85	T.C.	33.6	35.0	35.0	37.8	41.5	34.6	35.7	35.4	38.3	41.8	35.5	36.4	35.9	38.7	42.0
	S.C.	32.6	30.3	25.6	25.2	20.0	33.6	31.8	26.6	26.3	20.6	34.5	33.3	27.7	27.4	21.2
	K.W.	2.24	2.26	2.25	2.30	2.33	2.26	2.28	2.27	2.32	2.35	2.30	2.30	2.30	2.34	2.38
95	T.C.	32.5	33.4	33.2	36.1	39.4	33.3	34.0	33.7	36.6	39.6	34.0	34.5	34.2	37.1	39.8
	S.C.	31.6	29.4	24.7	24.3	19.4	32.3	31.0	25.6	25.6	19.9	33.0	32.4	26.6	26.9	20.3
	K.W.	2.50	2.52	2.51	2.55	2.59	2.52	2.53	2.53	2.57	2.60	2.56	2.56	2.56	2.59	2.63
105	T.C.	30.7	31.5	31.2	33.7	37.0	31.5	32.0	31.6	34.2	37.2	32.1	32.6	32.0	34.7	37.4
	S.C.	29.9	28.4	23.7	23.6	18.6	30.6	29.6	24.7	24.8	19.0	31.3	30.6	25.7	25.9	19.4
	K.W.	2.89	2.90	2.90	2.94	2.97	2.92	2.92	2.91	2.96	2.99	2.95	2.95	2.94	2.98	3.02
115	T.C.	29.0	29.6	29.2	31.3	34.7	29.7	30.2	29.5	31.8	34.9	30.4	30.7	29.8	32.3	35.0
	S.C.	28.3	27.5	22.8	22.9	17.9	29.0	28.2	23.8	23.9	18.2	29.6	28.9	24.8	24.9	18.5
	K.W.	3.28	3.28	3.27	3.32	3.35	3.30	3.29	3.29	3.33	3.37	3.33	3.32	3.31	3.35	3.40
125	T.C.	27.3	27.7	27.2	29.0	32.4	28.0	28.3	27.4	29.5	32.6	28.6	28.8	27.7	30.0	32.7
	S.C.	26.7	26.5	21.9	22.2	17.2	27.3	26.8	22.9	23.1	17.4	28.0	27.1	24.0	24.0	17.6
	K.W.	3.66	3.65	3.65	3.70	3.73	3.68	3.67	3.66	3.71	3.75	3.71	3.70	3.69	3.73	3.78

NOTE: ALL CAPACITIES ARE NET (KBTUH) WITH INDOOR FAN HEAT ALREADY DEDUCTED AT 1250 BTUH/1000 CFM.

**Multipliers for determining the performance with other indoor sections.**

NOTE: For dry bulb temperatures different than those listed (between 73-87 F), sensible capacity increases by 1060 BTUH per 1000 CFM per degree above the listed temperature and decreases by 1060 BTUH per 1000 CFM per degree below the listed temperature.

NOTE: KW RATING IS FOR OUTDOOR AND INDOOR UNITS.

**HIGH CFM**

Air Handler	Coil	T.C.	S.C.	KW
AV36C	-	0.97	0.97	1.03
MV12B	FC/MC/PC43B	0.98	0.98	1.03
MV12B	FC/MC/PC43C	0.98	0.98	1.03
MV16C	FC/MC/PC43C	0.99	0.99	1.01
MV12D	FC/MC/PC48D	0.98	0.98	1.00
MV12D	UC48D	0.98	0.98	1.00
MV16C	FC/MC/PC48C	0.99	0.99	1.00
MV16C	FC/MC/PC48D	0.99	0.99	1.00
MV16C	UC48D	0.99	0.99	1.00
MV20D	FC/MC/PC48D	1.00	1.00	1.00
MV20D	UC48D	1.00	1.00	1.00
MV12D	FC/MC62D	1.00	1.00	1.00
MV20D	FC/MC62D	1.01	1.01	1.00

Variable Speed Furnace	Coil	T.C.	S.C.	KW
PV8*A12	FC/MC/PC37A	0.98	0.98	1.05
PV9*A12	FC/MC/PC37A	0.97	0.97	1.07
PV8*B16	FC/MC/PC43B	0.98	0.98	1.02
PV8*B16	FC/MC/PC43C	0.98	0.98	1.02
PV8*C16	FC/MC/PC43C	0.99	0.99	1.02
PV8*C20	FC/MC/PC43C	0.98	0.98	1.04
P(C,V)9*B12	FC/MC/PC43B	0.97	0.97	1.05
P(C,V)9*B12	FC/MC/PC43C	0.97	0.97	1.05

Variable Speed Furnace	Coil	T.C.	S.C.	KW
P(C,V)9*C16	FC/MC/PC43C	0.98	0.98	1.02
P(C,V)9*C20	FC/MC/PC43C	0.98	0.98	1.03
PV8*C16	FC/MC/PC48C	0.99	0.99	1.01
PV8*C16	FC/MC/PC48D	0.99	0.99	1.01
PV8*C16	UC48D	0.99	0.99	1.01
PV8*C20	FC/MC/PC48C	0.99	0.99	1.04
PV8*C20	FC/MC/PC48D	0.99	0.99	1.04
PV8*C20	UC48D	0.99	0.99	1.04
P(C,V)9*C16	FC/MC/PC48C	0.99	0.99	1.02
P(C,V)9*C16	FC/MC/PC48D	0.99	0.99	1.02
P(C,V)9*C16	UC48D	0.99	0.99	1.02
P(C,V)9*C20	FC/MC/PC48C	0.99	0.99	1.03
P(C,V)9*C20	FC/MC/PC48D	0.99	0.99	1.03
P(C,V)9*C20	UC48D	0.99	0.99	1.03
P(C,V)9*D20	FC/MC/PC48D	0.99	0.99	1.02
P(C,V)9*D20	UC48D	0.99	0.99	1.02
PV8*C20	FC/MC62D	1.00	1.00	1.04
P(C,V)9*C20	FC/MC62D	1.00	1.00	1.03
P(C,V)9*D20	FC/MC62D	1.01	1.00	1.02
PV8*C16	HC42C	0.99	0.99	1.02
PV8*C20	HC42C	0.98	0.98	1.04
P(C,V)9*C16	HC42C	0.98	0.98	1.02
P(C,V)9*C20	HC42C	0.98	0.98	1.03

COOLING PERFORMANCE DATA - LOW CFM 1-STAGE OPERATION																
OUTDOOR UNIT MODEL NO.		CZH04811														
INDOOR COIL MODEL NO.		FC62D + MV20D														
CONDENSER ENTERING AIR TEMPERATURE	ID CFM	950					1000					1050				
	ID DB (°F)	80	80	75	80	80	80	80	75	80	80	80	80	75	80	80
	ID WB (°F)	57	62	62	67	72	57	62	62	67	72	57	62	62	67	72
65	T.C.	35.4	36.6	36.2	39.8	42.3	36.1	37.2	36.8	40.2	42.9	36.8	37.8	37.4	40.6	43.4
	S.C.	34.3	31.8	26.9	27.2	21.7	34.8	32.5	27.6	27.8	22.0	35.3	33.3	28.2	28.5	22.3
	K.W.	1.50	1.50	1.49	1.48	1.48	1.50	1.49	1.49	1.48	1.47	1.49	1.49	1.49	1.47	1.47
75	T.C.	34.0	34.9	34.5	37.8	40.4	34.6	35.4	35.0	38.2	40.9	35.2	36.0	35.5	38.6	41.5
	S.C.	32.9	31.0	26.2	26.4	21.0	33.4	31.7	26.8	27.0	21.3	33.9	32.4	27.4	27.6	21.7
	K.W.	1.81	1.81	1.81	1.80	1.79	1.81	1.81	1.80	1.79	1.78	1.80	1.80	1.80	1.79	1.78
85	T.C.	32.5	33.1	32.8	35.7	38.5	33.1	33.7	33.2	36.2	39.0	33.7	34.2	33.6	36.6	39.5
	S.C.	31.5	30.2	25.5	25.5	20.3	32.0	30.9	26.0	26.1	20.7	32.5	31.6	26.6	26.7	21.1
	K.W.	2.12	2.12	2.12	2.11	2.10	2.12	2.12	2.12	2.11	2.10	2.12	2.12	2.11	2.11	2.09
95	T.C.	31.1	31.4	31.1	33.7	36.6	31.7	31.9	31.4	34.2	37.1	32.2	32.4	31.7	34.6	37.6
	S.C.	30.1	29.4	24.8	24.7	19.6	30.6	30.1	25.3	25.3	20.0	31.1	30.8	25.8	25.8	20.4
	K.W.	2.44	2.44	2.44	2.43	2.41	2.43	2.43	2.43	2.43	2.41	2.43	2.43	2.43	2.42	2.40
105	T.C.	29.4	29.7	28.9	31.5	34.2	30.0	30.2	29.3	31.9	34.6	30.5	30.7	29.6	32.3	35.0
	S.C.	28.5	27.8	23.8	23.8	18.7	28.9	28.5	24.3	24.4	19.1	29.4	29.1	24.8	24.9	19.6
	K.W.	2.86	2.87	2.87	2.87	2.84	2.86	2.86	2.86	2.86	2.84	2.86	2.86	2.86	2.85	2.84
115	T.C.	27.8	28.0	26.9	29.3	31.9	28.4	28.6	27.2	29.7	32.2	28.9	29.1	27.6	30.1	32.5
	S.C.	26.9	26.3	22.9	23.0	17.8	27.4	26.9	23.4	23.5	18.3	27.8	27.5	23.9	24.1	18.7
	K.W.	3.28	3.28	3.29	3.29	3.26	3.27	3.28	3.28	3.27	3.26	3.27	3.27	3.28	3.27	3.26
125	T.C.	26.2	26.4	24.8	27.1	29.6	26.7	26.9	25.2	27.5	29.8	27.2	27.5	25.6	27.9	30.0
	S.C.	25.4	24.8	21.9	22.1	16.9	25.8	25.4	22.4	22.7	17.4	26.2	26.0	22.9	23.3	17.9
	K.W.	3.69	3.70	3.71	3.71	3.67	3.69	3.69	3.70	3.69	3.67	3.69	3.69	3.70	3.68	3.68

NOTE: ALL CAPACITIES ARE NET (KBTUH) WITH INDOOR FAN HEAT ALREADY DEDUCTED AT 1250 BTUH/1000 CFM.

### Multipliers for determining the performance with other indoor sections.

NOTE: For dry bulb temperatures different than those listed (between 73-87 F), sensible capacity increases by 1060 BTUH per 1000 CFM per degree above the listed temperature and decreases by 1060 BTUH per 1000 CFM per degree below the listed temperature.

NOTE: KW RATING IS FOR OUTDOOR AND INDOOR UNITS.

### LOW CFM

Air Handler	Coil	T.C.	S.C.	KW
AV/SV48D	-	0.97	0.97	1.00
AV/SV60D	-	0.97	0.97	1.00
F4FV060	-	0.99	0.98	1.01
MV16C	FC/MC/PC48C	1.00	1.00	0.99
MV16C	FC/MC/PC48D	1.00	1.00	0.99
MV16C	UC48D	1.00	1.00	0.99
MV20D	FC/MC/PC48D	1.00	1.00	1.00
MV20D	UC48D	1.00	1.00	1.00
MV20D	FC/MC62D	1.00	1.00	1.00

Variable Speed Furnace	Coil	T.C.	S.C.	KW
PV8*C16	FC/MC/PC48C	0.97	0.97	0.98
PV8*C16	FC/MC/PC48D	0.97	0.97	0.98
PV8*C16	UC48D	0.97	0.97	0.98
PV8*C20	FC/MC/PC48C	1.00	1.00	0.99
PV8*C20	FC/MC/PC48D	1.00	1.00	0.99
PV8*C20	UC48D	1.00	1.00	0.99
P(C,V)9*C16	FC/MC/PC48C	1.01	1.02	0.98
P(C,V)9*C16	FC/MC/PC48D	1.01	1.02	0.98
P(C,V)9*C16	UC48D	1.01	1.02	0.98
P(C,V)9*C20	FC/MC/PC48C	0.99	0.99	1.00
P(C,V)9*C20	FC/MC/PC48D	0.99	0.99	1.00
P(C,V)9*C20	UC48D	0.99	0.99	1.00
P(C,V)9*D20	FC/MC/PC48D	0.99	0.99	1.00
P(C,V)9*D20	UC48D	0.99	0.99	1.00
PV8*C20	FC/MC62D	1.00	1.00	0.99
P(C,V)9*C20	FC/MC62D	1.00	1.00	1.00
P(C,V)9*D20	FC/MC62D	0.99	0.99	1.00
P(C,V)9*D20	HC60D	0.95	0.95	1.00

<b>COOLING PERFORMANCE DATA - HIGH CFM 2-STAGE OPERATION</b>																
<b>OUTDOOR UNIT MODEL NO.</b>		<b>CZH04811</b>														
<b>INDOOR COIL MODEL NO.</b>		<b>FC62D + MV20D</b>														
<b>CONDENSER ENTERING AIR TEMPERATURE</b>	<b>ID CFM</b>	<b>1500</b>					<b>1600</b>					<b>1700</b>				
	<b>ID DB (°F)</b>	80	80	75	80	80	80	80	75	80	80	80	80	75	80	80
	<b>ID WB (°F)</b>	57	62	62	67	72	57	62	62	67	72	57	62	62	67	72
65	T.C.	48.7	49.9	49.0	53.2	56.4	49.6	50.4	49.5	54.4	56.8	50.5	50.9	50.0	55.5	57.2
	S.C.	48.0	44.9	38.2	37.9	29.7	48.9	46.3	39.1	39.0	30.3	49.7	47.6	40.0	40.1	30.9
	K.W.	2.53	2.57	2.56	2.64	2.71	2.58	2.61	2.61	2.67	2.75	2.64	2.67	2.66	2.72	2.79
75	T.C.	46.8	47.7	46.8	50.9	53.6	47.6	48.2	47.2	51.8	54.0	48.3	48.8	47.6	52.5	54.4
	S.C.	46.2	43.8	37.1	36.8	28.7	46.9	45.0	38.0	37.9	29.3	47.6	46.2	38.9	38.9	29.9
	K.W.	2.89	2.91	2.90	2.98	3.05	2.93	2.96	2.95	3.02	3.09	2.99	3.01	3.00	3.07	3.15
85	T.C.	45.0	45.5	44.5	48.6	50.9	45.6	46.1	44.9	49.1	51.3	46.2	46.6	45.2	49.6	51.6
	S.C.	44.3	42.6	35.9	35.7	27.8	44.9	43.7	36.9	36.7	28.4	45.6	44.8	37.8	37.7	28.9
	K.W.	3.24	3.26	3.25	3.33	3.40	3.29	3.31	3.29	3.37	3.44	3.34	3.36	3.34	3.42	3.50
95	T.C.	43.1	43.4	42.2	46.3	48.2	43.5	43.9	42.5	46.5	48.5	44.0	44.4	42.9	46.6	48.8
	S.C.	42.4	41.5	34.8	34.6	26.9	43.0	42.4	35.7	35.6	27.4	43.5	43.3	36.7	36.5	27.9
	K.W.	3.59	3.61	3.60	3.68	3.75	3.64	3.66	3.64	3.72	3.79	3.69	3.71	3.69	3.77	3.85
105	T.C.	40.7	41.0	39.6	43.5	45.2	41.2	41.5	39.9	43.7	45.4	41.6	41.9	40.1	43.9	45.6
	S.C.	40.1	39.3	33.5	33.5	25.8	40.6	40.1	34.4	34.4	26.3	41.1	40.8	35.4	35.3	26.8
	K.W.	4.10	4.12	4.10	4.18	4.25	4.15	4.16	4.14	4.22	4.29	4.21	4.22	4.19	4.27	4.35
115	T.C.	38.5	38.7	37.2	40.7	42.4	38.9	39.1	37.3	40.9	42.5	39.3	39.5	37.4	41.2	42.5
	S.C.	37.9	37.2	32.3	32.4	24.9	38.4	37.8	33.2	33.3	25.3	38.8	38.4	34.1	34.2	25.7
	K.W.	4.60	4.60	4.58	4.67	4.74	4.65	4.65	4.62	4.71	4.78	4.70	4.71	4.67	4.76	4.83
125	T.C.	36.2	36.4	34.7	37.9	39.6	36.6	36.8	34.7	38.2	39.6	36.9	37.1	34.7	38.4	39.5
	S.C.	35.7	35.1	31.1	31.3	23.9	36.1	35.6	32.0	32.2	24.3	36.5	36.0	32.8	33.1	24.6
	K.W.	5.09	5.09	5.07	5.16	5.23	5.14	5.14	5.11	5.20	5.27	5.20	5.21	5.16	5.25	5.32

NOTE: ALL CAPACITIES ARE NET (KBTUH) WITH INDOOR FAN HEAT ALREADY DEDUCTED AT 1250 BTUH/1000 CFM.

### Multipliers for determining the performance with other indoor sections

NOTE: For dry bulb temperatures different than those listed (between 73-87 F), sensible capacity increases by 1060 BTUH per 1000 CFM per degree above the listed temperature and decreases by 1060 BTUH per 1000 CFM per degree below the listed temperature.

NOTE: KW RATING IS FOR OUTDOOR AND INDOOR UNITS.

### HIGH CFM

<b>Air Handler</b>	<b>Coil</b>	<b>T.C.</b>	<b>S.C.</b>	<b>KW</b>
AV/SV48D	–	0.96	0.96	0.99
AV/SV60D	–	0.96	0.96	0.99
F4FV060	–	0.96	0.96	0.98
MV16C	FC/MC/PC48C	0.99	0.99	0.99
MV16C	FC/MC/PC48D	0.99	0.99	0.99
MV16C	UC48D	0.99	0.99	0.99
MV20D	FC/MC/PC48D	0.99	0.99	1.00
MV20D	UC48D	0.99	0.99	1.00
MV20D	FC/MC62D	1.00	1.00	1.00

<b>Variable Speed Furnace</b>	<b>Coil</b>	<b>T.C.</b>	<b>S.C.</b>	<b>KW</b>
PV8*C16	FC/MC/PC48C	0.97	0.97	1.01
PV8*C16	FC/MC/PC48D	0.97	0.97	1.01
PV8*C16	UC48D	0.97	0.97	1.01
PV8*C20	FC/MC/PC48C	0.98	0.98	1.02
PV8*C20	FC/MC/PC48D	0.98	0.98	1.02
PV8*C20	UC48D	0.98	0.98	1.02
P(C,V)9*C16	FC/MC/PC48C	0.98	0.98	1.03
P(C,V)9*C16	FC/MC/PC48D	0.98	0.98	1.03
P(C,V)9*C16	UC48D	0.98	0.98	1.03
P(C,V)9*C20	FC/MC/PC48C	0.98	0.98	1.02
P(C,V)9*C20	FC/MC/PC48D	0.98	0.98	1.02
P(C,V)9*C20	UC48D	0.98	0.98	1.02
P(C,V)9*D20	FC/MC/PC48D	0.98	0.98	1.00
P(C,V)9*D20	UC48D	0.98	0.98	1.00
PV8*C20	FC/MC62D	0.99	0.99	1.01
P(C,V)9*C20	FC/MC62D	0.99	0.99	1.02
P(C,V)9*D20	FC/MC62D	0.99	0.99	1.01
P(C,V)9*D20	HC60D	0.95	0.95	1.00

<b>COOLING PERFORMANCE DATA - LOW CFM 1-STAGE OPERATION</b>																
<b>OUTDOOR UNIT MODEL NO.</b>		<b>CZH06011</b>														
<b>INDOOR COIL MODEL NO.</b>		<b>FC62D + MV20D</b>														
<b>CONDENSER ENTERING AIR TEMPERATURE</b>	<b>ID CFM</b>	<b>1100</b>					<b>1150</b>					<b>1200</b>				
	<b>ID DB (°F)</b>	80	80	75	80	80	80	80	75	80	80	80	80	75	80	80
	<b>ID WB (°F)</b>	57	62	62	67	72	57	62	62	67	72	57	62	62	67	72
65	T.C.	38.1	44.0	43.9	47.7	52.4	39.7	44.2	44.3	48.1	53.0	41.4	44.3	44.7	48.5	53.5
	S.C.	37.2	35.7	30.6	30.0	24.5	38.8	36.5	31.2	30.6	24.9	40.4	37.3	31.7	31.2	25.3
	K.W.	3.20	1.94	1.94	1.91	1.92	2.79	1.94	1.94	1.91	1.90	2.37	1.95	1.94	1.92	1.88
75	T.C.	37.5	42.0	42.0	45.7	50.2	39.2	42.4	42.3	46.1	50.8	40.8	42.8	42.7	46.5	51.3
	S.C.	36.6	35.0	29.8	29.4	23.8	38.2	35.8	30.4	30.0	24.2	39.8	36.6	30.9	30.6	24.6
	K.W.	3.20	2.36	2.36	2.33	2.34	2.78	2.36	2.36	2.34	2.32	2.37	2.37	2.36	2.35	2.31
85	T.C.	37.0	40.1	40.0	43.8	48.1	38.6	40.7	40.4	44.2	48.6	40.2	41.3	40.7	44.5	49.1
	S.C.	36.1	34.2	29.0	28.7	23.1	37.7	35.0	29.6	29.3	23.5	39.2	35.8	30.1	29.9	23.8
	K.W.	3.20	2.78	2.78	2.75	2.76	2.78	2.78	2.78	2.76	2.75	2.37	2.78	2.78	2.77	2.74
95	T.C.	36.5	38.2	38.1	41.9	45.9	38.1	39.0	38.4	42.2	46.4	39.7	39.8	38.7	42.5	46.9
	S.C.	35.6	33.5	28.2	28.1	22.4	37.1	34.3	28.8	28.7	22.7	38.7	35.0	29.3	29.2	23.1
	K.W.	3.20	3.19	3.20	3.17	3.17	2.78	3.20	3.20	3.18	3.17	2.37	3.20	3.20	3.19	3.17
105	T.C.	34.2	35.5	35.3	38.8	42.7	35.4	36.1	35.6	39.1	43.1	36.6	36.7	35.8	39.3	43.5
	S.C.	33.4	31.9	26.7	26.8	21.0	34.6	32.6	27.3	27.3	21.4	35.7	33.2	27.8	27.8	21.8
	K.W.	3.76	3.75	3.75	3.73	3.73	3.48	3.75	3.75	3.74	3.73	3.20	3.76	3.76	3.75	3.74
115	T.C.	32.0	32.9	32.6	35.8	39.7	32.8	33.3	32.9	36.0	39.9	33.5	33.7	33.1	36.3	40.2
	S.C.	31.3	30.4	25.3	25.4	19.7	32.0	30.9	25.9	25.9	20.1	32.8	31.5	26.4	26.4	20.5
	K.W.	4.30	4.29	4.29	4.28	4.28	4.16	4.29	4.29	4.28	4.28	4.02	4.29	4.29	4.29	4.28
125	T.C.	29.9	30.3	30.0	32.7	36.6	30.2	30.5	30.1	33.0	36.7	30.5	30.6	30.3	33.2	36.9
	S.C.	29.2	28.9	23.9	24.1	18.3	29.5	29.3	24.4	24.5	18.8	29.8	29.7	24.9	24.9	19.3
	K.W.	4.84	4.82	4.83	4.83	4.83	4.83	4.83	4.83	4.83	4.83	4.83	4.83	4.83	4.83	4.83

NOTE: ALL CAPACITIES ARE NET (KBTUH) WITH INDOOR FAN HEAT ALREADY DEDUCTED AT 1250 BTUH/1000 CFM.

### Multipliers for determining the performance with other indoor sections.

NOTE: For dry bulb temperatures different than those listed (between 73-87 F), sensible capacity increases by 1060 BTUH per 1000 CFM per degree above the listed temperature and decreases by 1060 BTUH per 1000 CFM per degree below the listed temperature.

NOTE: KW RATING IS FOR OUTDOOR AND INDOOR UNITS.

### LOW CFM

<b>Air Handler</b>	<b>Coil</b>	<b>T.C.</b>	<b>S.C.</b>	<b>KW</b>
AV/SV60D	—	0.99	0.99	1.00
F4FV060	—	0.99	0.99	1.02
MV20D	FC/MC/PC60D	0.95	0.95	1.00
MV20D	UC60D	0.95	0.95	1.00
MV20D	FC/MC62D	1.00	1.00	1.00

<b>Variable Speed Furnace</b>	<b>Coil</b>	<b>T.C.</b>	<b>S.C.</b>	<b>KW</b>
PV8*C20	FC/PC60C	0.97	0.97	1.01
PV8*C20	FC/MC/PC60D	0.97	0.97	1.01
PV8*C20	UC60D	0.97	0.97	1.01
P(C,V)9*C20	FC/PC60C	0.96	0.96	1.01
P(C,V)9*C20	FC/MC/PC60D	0.96	0.96	1.01
P(C,V)9*C20	UC60D	0.96	0.96	1.01
P(C,V)9*D20	FC/MC/PC60D	0.95	0.95	1.00
P(C,V)9*D20	UC60D	0.95	0.95	1.00
PV8*C20	FC/MC62D	1.02	1.02	1.01
P(C,V)9*C20	FC/MC62D	1.01	1.01	1.00
P(C,V)9*D20	FC/MC62D	1.00	1.00	1.00
P(C,V)9*D20	HC60D	0.95	0.95	1.00

## COOLING PERFORMANCE DATA - HIGH CFM 2-STAGE OPERATION

OUTDOOR UNIT MODEL NO.		CZH06011														
INDOOR COIL MODEL NO.		FC62D + MV20D														
CONDENSER ENTERING AIR TEMPERATURE	ID CFM	1750					1850					1950				
	ID DB (°F)	80	80	75	80	80	80	80	75	80	80	80	80	75	80	80
	ID WB (°F)	57	62	62	67	72	57	62	62	67	72	57	62	62	67	72
65	T.C.	57.1	61.0	60.6	66.2	71.1	58.0	61.4	61.2	66.8	72.2	58.8	61.6	61.8	67.3	73.3
	S.C.	58.1	53.7	44.6	44.7	36.4	59.0	54.7	46.2	45.8	36.6	59.8	55.6	47.7	46.8	36.8
	K.W.	3.20	3.25	3.26	3.32	3.36	3.27	3.32	3.31	3.39	3.44	3.36	3.40	3.38	3.47	3.53
75	T.C.	55.3	58.5	58.0	63.4	68.2	56.0	58.8	58.4	63.9	68.9	56.7	59.1	58.7	64.3	69.5
	S.C.	56.3	52.5	43.9	43.6	34.8	57.0	53.5	44.9	44.6	34.9	57.7	54.5	45.8	45.6	34.9
	K.W.	3.69	3.74	3.74	3.80	3.86	3.77	3.80	3.79	3.87	3.93	3.85	3.88	3.86	3.95	4.01
85	T.C.	53.6	55.9	55.4	60.6	65.3	54.1	56.2	55.5	60.9	65.5	54.6	56.5	55.6	61.2	65.8
	S.C.	54.5	51.3	43.2	42.5	33.1	55.1	52.4	43.6	43.5	33.1	55.6	53.4	44.0	44.4	33.0
	K.W.	4.19	4.23	4.22	4.29	4.35	4.26	4.29	4.28	4.35	4.41	4.34	4.36	4.35	4.43	4.49
95	T.C.	51.8	53.3	52.8	57.8	62.4	52.2	53.6	52.7	58.0	62.2	52.6	53.9	52.5	58.2	62.0
	S.C.	52.7	50.1	42.5	41.5	31.5	53.1	51.3	42.4	42.3	31.4	53.5	52.4	42.1	43.2	31.2
	K.W.	4.69	4.71	4.70	4.77	4.84	4.76	4.77	4.76	4.83	4.90	4.83	4.85	4.83	4.91	4.97
105	T.C.	48.6	49.8	49.3	53.9	58.3	49.1	50.1	49.3	54.1	58.2	49.5	50.4	49.2	54.2	58.1
	S.C.	49.5	47.7	40.5	39.8	30.1	50.0	48.7	40.7	40.6	30.1	50.4	49.6	40.8	41.3	30.1
	K.W.	5.39	5.40	5.38	5.46	5.54	5.46	5.47	5.44	5.53	5.60	5.54	5.55	5.52	5.60	5.67
115	T.C.	45.6	46.3	46.0	50.2	54.3	46.1	46.7	46.0	50.3	54.3	46.5	47.1	46.0	50.4	54.2
	S.C.	46.4	45.4	38.6	38.2	28.7	46.9	46.2	39.0	38.9	29.0	47.4	46.9	39.4	39.6	29.1
	K.W.	6.06	6.07	6.04	6.13	6.22	6.14	6.14	6.11	6.20	6.28	6.23	6.22	6.19	6.28	6.36
125	T.C.	42.6	42.8	42.6	46.4	50.3	43.1	43.3	42.7	46.5	50.4	43.5	43.7	42.7	46.5	50.4
	S.C.	43.4	43.2	36.6	36.6	27.4	43.9	43.7	37.4	37.2	27.8	44.3	44.1	38.1	37.8	28.2
	K.W.	6.74	6.75	6.71	6.80	6.89	6.82	6.82	6.78	6.87	6.96	6.91	6.90	6.86	6.96	7.04

NOTE: ALL CAPACITIES ARE NET (KBTUH) WITH INDOOR FAN HEAT ALREADY DEDUCTED AT 1250 BTUH/1000 CFM.

### Multipliers for determining the performance with other indoor sections.

NOTE: For dry bulb temperatures different than those listed (between 73-87 F), sensible capacity increases by 1060 BTUH per 1000 CFM per degree above the listed temperature and decreases by 1060 BTUH per 1000 CFM per degree below the listed temperature.

NOTE: KW RATING IS FOR OUTDOOR AND INDOOR UNITS.

### HIGH CFM

Air Handler	Coil	T.C.	S.C.	KW
AV/SV60D	-	0.96	0.96	0.99
F4FV060	-	0.96	0.96	0.99
MV20D	FC/MC/PC60D	0.96	0.96	0.99
MV20D	UC60D	0.96	0.96	0.99
MV20D	FC/MC62D	1.00	1.00	1.00

Variable Speed Furnace	Coil	T.C.	S.C.	KW
PV8*C20	FC/PC60C	0.95	0.95	1.00
PV8*C20	FC/MC/PC60D	0.95	0.95	1.00
PV8*C20	UC60D	0.95	0.95	1.00
P(C,V)9*C20	FC/PC60C	0.93	0.93	0.99
P(C,V)9*C20	FC/MC/PC60D	0.93	0.93	0.99
P(C,V)9*C20	UC60D	0.93	0.93	0.99
P(C,V)9*D20	FC/MC/PC60D	0.93	0.93	0.98
P(C,V)9*D20	UC60D	0.93	0.93	0.98
PV8*C20	FC/MC62D	0.98	0.98	1.01
P(C,V)9*C20	FC/MC62D	0.97	0.97	1.00
P(C,V)9*D20	FC/MC62D	0.97	0.97	0.99
P(C,V)9*D20	HC60D	0.94	0.94	0.98